



Undercounter Freezer

UUC-60F: Flat Top, Double Door



Model Number:
UUC-60F

Durable Design

Stainless steel interior
exterior

Adjustable, Heavy-duty,
Anticorrosion shelving

Created to endure the
everyday stress of the
kitchen environment to
protect your long-term
investment and guarantee
superior food preservation.

Workmanship

Designed for mobility,
reliability and efficiency in
commercial kitchens

Certified with UL, NSF, & CE
guaranteeing efficiency and
quality standards

5" castors with brakes;
ideal for wet and corrosive
environments

Fits under counters to
maximize your floor space

Easy to grip handle

Entirely self-contained system

Energy Efficient

Self-closing door that seals
tight with magnetic vinyl
gaskets

Foamed-in-place high density
polyurethane insulated body

Superb refrigerant system
that uses environmentally
safe HCFC refrigerant



(888) 556-2112

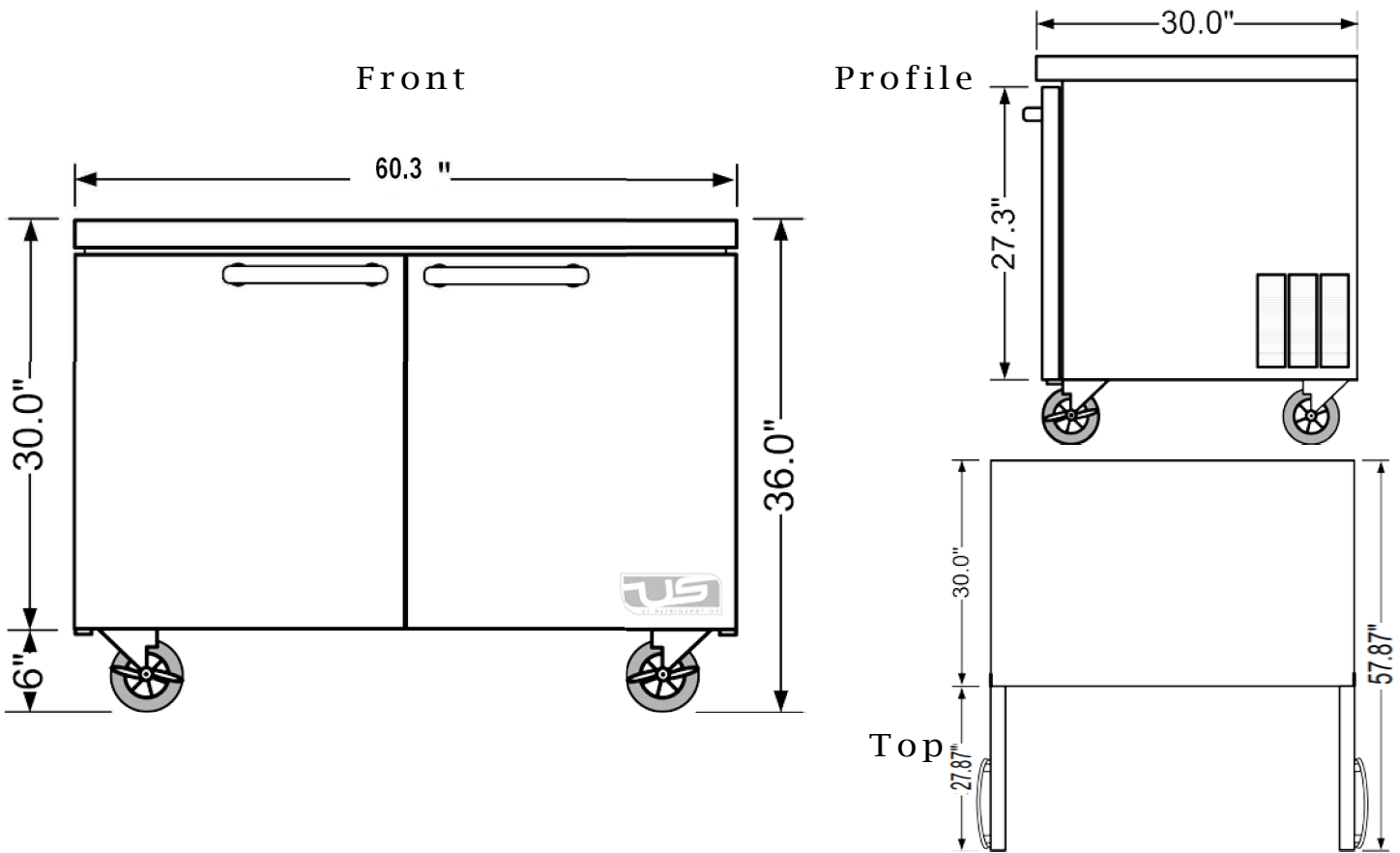

Model Number	UUC-60F
Description	Double Door, Undercounter Freezer
Interior / Exterior Material	Stainless Steel
Number of Doors	2
Number of Shelves	4
Capacity (cubic feet)	16
Exterior Dimensions W x D x H (in.)	60.3x 30.0 x 36.0
Compressor Size (HP)	1/2
Voltage / Frequency	115V / 60Hz
Amps	8.9
Working Temperature	-1 F to -11F
Refrigerant	R404a
Crated Weight (lbs.)	349

