



## Sandwich & Salad Prep Tables

### USSU-72-18: Triple Door

Model Number:  
USSU-72-18



#### Durable Design

Stainless steel interior, exterior & food containers

Adjustable, Heavy-duty, Anticorrosion shelving

Removable, easy to clean cutting board

Created to endure the everyday stress of the kitchen environment to protect your long-term investment and guarantee superior food preservation.

#### Workmanship

Designed for mobility, reliability and efficiency in commercial kitchens

Certified with UL, NSF, & CE guaranteeing efficiency and quality standards

5" castors with brakes; ideal for wet and corrosive environments

36" high for a comfortable working surface

Easy to grip handle

Entirely self-contained system

#### Energy Efficient

Self-closing door that seals tight with magnetic vinyl gaskets

Foamed-in-place high density polyurethane insulated body

Superb refrigerant system that uses environmentally safe HCFC refrigerant



(888) 556-2112

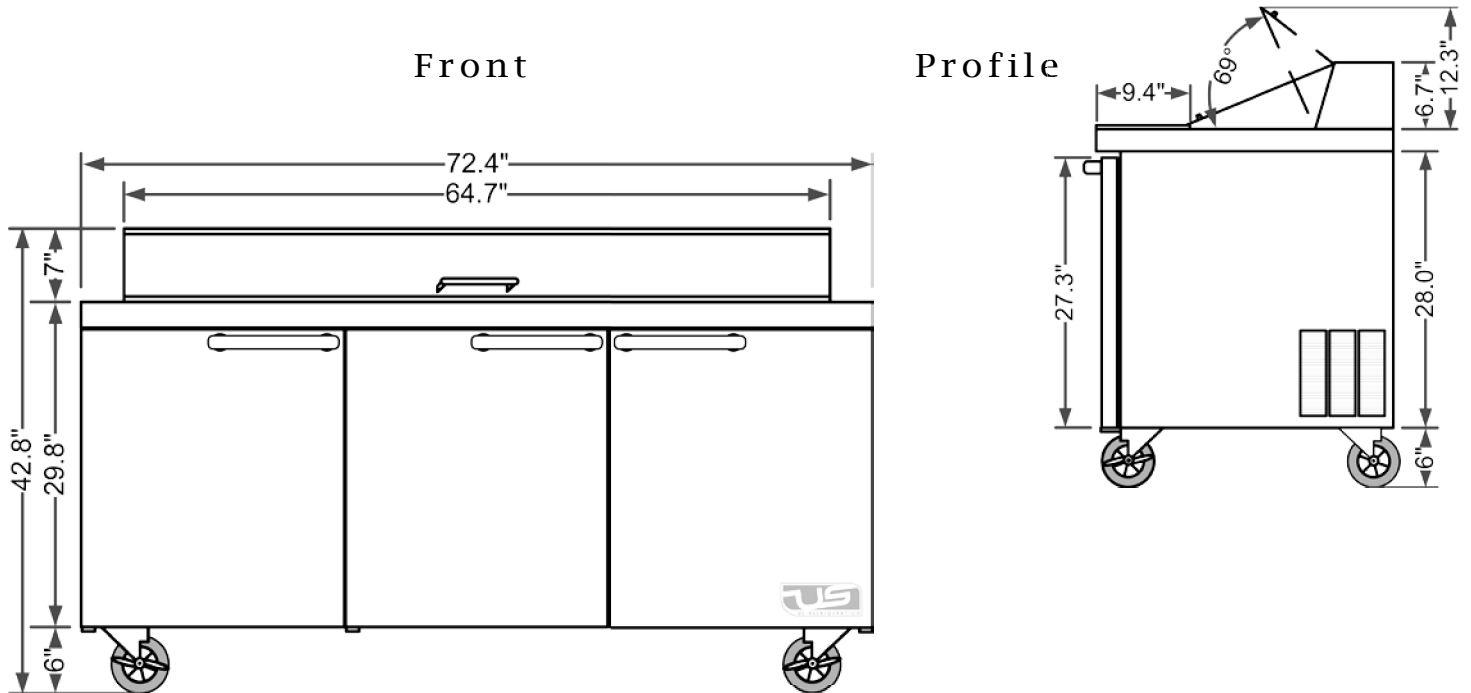

Model Number	USSU-72-18
Description	<b>Triple Door Refrigerated Sandwich / Salad Prep Table</b>
Interior / Exterior Material	Stainless Steel
Number of Doors	3
Number of Shelves	3
Capacity (cubic feet)	19.6
Exterior Dimensions W x D x H (in.)	72.4 x 30.0 x 42.8
Compressor Size (HP)	3/8
Voltage / Frequency	115V / 60Hz
Amps	9.9
Working Temperature	30 F to 44 F
Refrigerant	R134a
Crated Weight (lbs.)	383

