

CP171SS

79.0" x 23.63" x 23.75" (H x W x D)

Thin-line top refrigerator with a bottom freezer, cycle defrost, and stainless steel door

Highlights:

- A bottom freezer makes storage more convenient
- Dual compressor design for independent cooling of refrigerator and freezer
- Keep ice cream frozen in a zero degree freezer
- Ideal 24 inch footprint offers large capacity in slim fit



Bottom freezer	Convenient design with energy efficiency
Cycle defrost	Combines an automatic defrosting refrigerator with a manual defrost freezer to save unit energy and user maintenance
Energy efficient	Cycle defrost and freezer design uses less energy than standard refrigerator-freezers
Three slide-out drawers	Unique freezer design features transparent drawers for easy organization and better cold conditions
Stainless steel doors	Durable stainless steel adds luxury to any setting
Designer handles	Modern triangular handles add style and convenience to the exterior
Large capacity	12 c.f. of storage space inside a slim 24 inch width
Adjustable glass shelves	Rearrange your refrigerator space to accommodate all shapes and sizes or remove shelves for a simple clean-up
Dual evaporator cooling	Two compressors provides independent cooling of the refrigerator and freezer
Two adjustable thermostats	Manage the interior temperature with ease and accuracy

Specifications:

Height	79.0"
Width	23.63"
Depth	23.75"
Capacity	12.0 cu.ft.
Ext Depth with Handle	25.5"
Interior Height 1	35.25"
Interior Width 1	19.75"
Interior Depth 1	18.5"
Interior Height 2	25.38"
Interior Width 2	17.13"
Interior Depth 2	15.5"
Shipping Weight	251.0 lbs.
Weight	190.0 lbs.
Voltage/Frequency	115 V AC/60 Hz
Energy Usage/Year	547.0 kWh/year
US Electrical Safety	UL
Door Swing	RHD
Reversible	Yes
Crisper Quantity	2
Shelf Quantity	4
Adjustable Shelf	true
Shelf Type	Glass
Crisper Finish	Transparent
Drawer Quantity	3
Wheel Quantity	2
Defrost Type	Cycle
Depth with door at 90°	46.13"
Thermostat Type	Dial
Fan Type	Interior
Condensor Location	Side of Unit
Light	true
Level Legs Quantity	2
Parts/Labor Warranty	1 Year
Compressor Warranty	5 Years

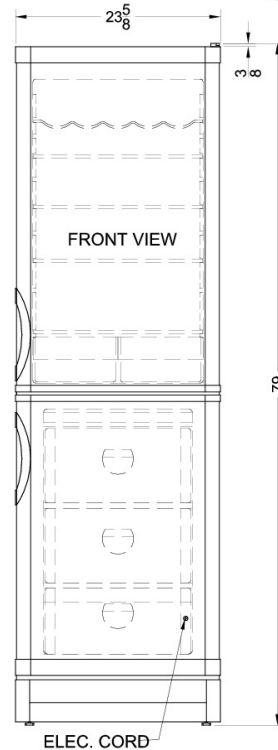
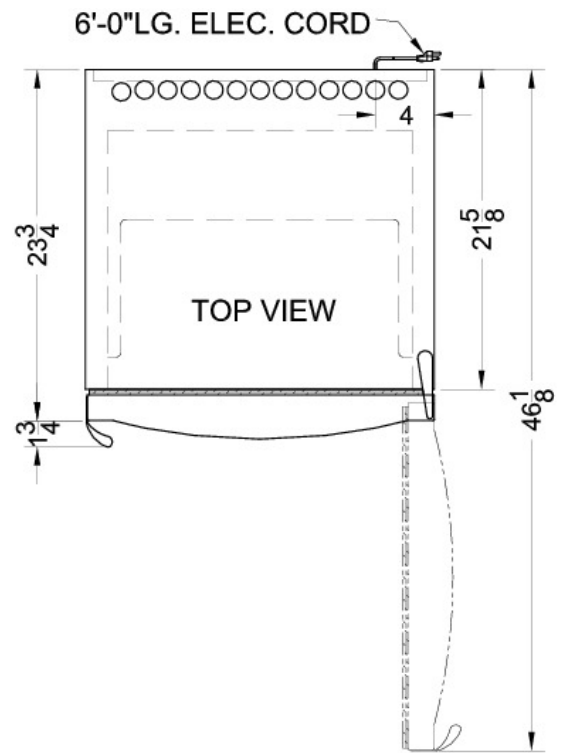

Summit Appliance Division, Felix Storch, Inc.
 770 Garrison Ave • Bronx, NY 10474
 Phone: 718-893-3900 • Fax: 718-842-3093
 Email: info@summitappliance.com