

DELUX DIPPING CABINET



Caravell DDC-52

FEATURES

- ▶ **Internal Light for enhanced product display**
- ▶ Anti-fog tempered glass sliding lids
- ▶ Curved tempered glass sneeze guard
- ▶ White powder coated, baked on enamel exterior
- ▶ Aluminum interior
- ▶ Tubholders and skirts
- ▶ Dual t-stat temp range +0° to +40°F
- ▶ Bottom drain with plug
- ▶ Heavy duty dual casters
- ▶ Dipper well installation ready
- ▶ Refrigerant CFC-free R-134a
- ▶ 8-ft power cord and plug set

Standard Features

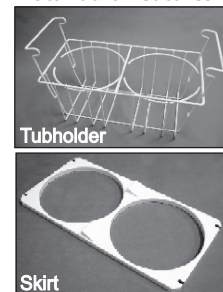

OPTIONS

- ▶ Lock for lids
- ▶ Locking casters
- ▶ Dipper well
- ▶ Custom graphics

SPECIFICATIONS

Model	Tubholders & Skirts	Display / Storage	External Dimensions W x D x H	Gross Cu Ft	Net Cu Ft	Shipping Weight	Amps	H/P	Electrical
DDC-30	2 / 2	4 / 2	29.5" x 25.5" x 52.5"	6.7	5.3	165	3.0	1/4	115/120V, 60Hz
DDC-41	3 / 3	6 / 4	41.0" x 25.5" x 52.5"	10.4	8.3	189	4.0	1/4	115/120V, 60Hz
DDC-52	4 / 4	8 / 6	51.5" x 25.5" x 52.5"	13.7	11.0	244	5.0	1/3	115/120V, 60Hz
DDC-61	5 / 5	10 / 8	60.5" x 25.5" x 52.5"	16.6	13.4	262	6.0	3/8	115/120V, 60Hz
DDC-70	6 / 6	12 / 10	69.8" x 25.5" x 52.5"	19.5	15.9	290	6.0	3/8	115/120V, 60Hz

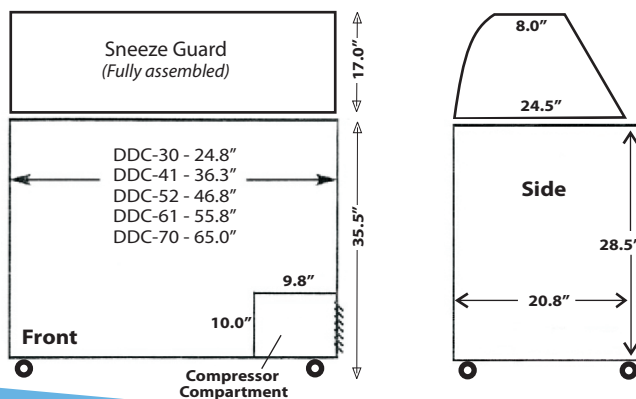

WARRANTY

18 Months Parts and Labor
5 Years Compressor (part only)

Administered by:
Metalfrío Solutions
(888) 403-0070 Toll Free

