

COUNTERTOP FREEZER

Excellent Point-of-Sale Merchandiser



CTF-2



CTF-3

FEATURES

- ▶ Durable white baked on enamel finish
- ▶ Insulated, heat-reflective, tempered glass door
- ▶ Internal top-mounted light for product display
- ▶ Light switch at back of unit
- ▶ Recessed handle in door frame
- ▶ Adjustable shelves
- ▶ Ventilation spacer to ensure proper airflow
- ▶ Built in lock with keys
- ▶ Freezer temperature range 0 to -13° F
- ▶ Refrigerant CFC-free R-134a

OPTIONS

- ▶ Hanging thermometer
- ▶ Custom graphics

SPECIFICATIONS

Model	Shelves (Adj)	External Dimensions W x D x H	Gross Cu Ft	Net Weight	Shipping Weight	Amps	H/P	Electrical
CTF-2	2	22.5" x 21.4" x 21.2"	1.8	116	100	1.9	1/6	115/120v, 60Hz
CTF-3	3	24.1" x 21.4" x 27.2"	3.2	132	150	3.6	1/4	115/120v, 60Hz

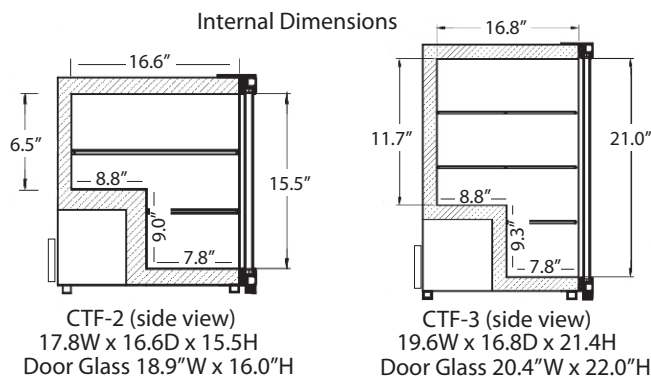

WARRANTY

18 Months Parts and Labor
5 Years Compressor (part only)

Administered by:
Metalfrio Solutions
(888) 403-0070 Toll Free



Certified to ANSI/NSF 7 Standards